



Dardanup  
Aeromodellers  
Society (Inc.)

# AIR-FLOW

Editor: Ron Fahlbusch.

Email: [aron90@bigpond.com](mailto:aron90@bigpond.com)

<http://dams.org.au/>

051011

2011/12 Committee:

President: Noel Cavanagh    Secretary: Kerry Forsyth    Treasurer: Stephen Peacock  
Safety: Ron Fahlbusch    P.R./Website: Jason Fletcher

Another month gone by. Start thinking seriously about Christmas presents. There is so much available right now and prices are way down. Everyone in your family deserves a new aeroplane or some new tools, so thinking caps on. No, that's a bit selfish, but it is bargain time if you look around.

It has been said that Gremlins bring bad things. Certainly in the case of Graeme Cattach's electric Chipie, whose pilot was receiving preflight instructions in last issue. The Chipie, without direction dived at Terra Firma during a later flight and was destroyed. This seems to be a relatively common occurrence over the years, mostly without apparent cause. The issue may be associated with low level air disturbance. When an aircraft is travelling slowly, and enters an area where airflow has slowed down relative to the 'plane, there can be an instant and severe stall. We can not see the airflow, but we can note the conditions of the day, and keep it filed away to maybe save us next time, Low and slow can get very dangerous in the wrong conditions. Be interesting to find out how many pilots have been caught out at our site. The Editor is first in line.

Our first D.L. Engines Bronze Wings \$20 voucher has been won by Thomas Greff. Congratulations Thomas, well done. I am sure that you will develop your obvious talent and have many years of great flying.. I hear that an older flyer or two

will be claiming their Bronze Wings soon too. I think everyone remembers a feeling of real achievement the day they gained their wings. It is among one of the harder things to do.

Congratulations to our trainers Larry Allen and Kerry Forsythe too, they put in a lot of work behind the scenes to ease the new pilots' way.

This month there is some good info on flying approaches courtesy of M.A.N. magazine. Even though we have been flying for a long time, a refresher never goes astray, and this is a timely and well written article. Due to space there are only a couple of pages shown. For more go to the Dams Website.

For those that haven't heard, a meeting was held with a representative of the Dardanup Council concerning future developments at the field. No further incursions will be made on our area in the next twelve months, and work is ongoing to level previously mined ground. We hope that this will allow a gradual transition to the new area, so that facilities can be moved when the time comes to an already established grassed new strip. The Eaton oval is to be stripped and the material deposited as fill to hopefully give a good start. An idea is to move the pits such that flyers no longer have the morning sun in their eyes. The club was given a very positive review, and the comment made that our members have achieved much more than the Council anticipated.

The Council offered to repair the storm damaged track in, and have wasted no time in doing so. It is great to have such a level of support, and the Club can look forward to the future with a high level of confidence.

And don't forget the SWARMS Scale Day at the end of October. There will be some great models and a good chance to get together with some flyers from other clubs.

That's it for this month.



## A DAY IN THE LIFE OF A FRIGHT INSTRUCTOR



PRE - FLIGHT CHECK LIST?



'PRE' MEANS 'BEFORE'



JUST ADD THROTTLE AND PULL BACK GENTLY.

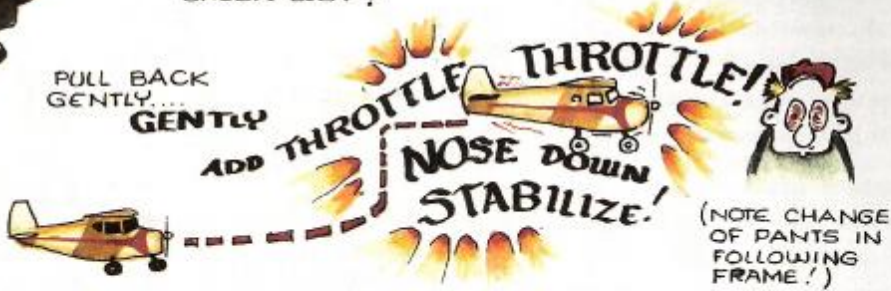

OK TODAY WE WORK ON STALLS.



YOU CAN ENTER THE STALL WHEN YOU ARE READY CRISTI!

ANYTIME YOU WANT TO.....



WHENEVER YOU ARE GOOD AND READY.



SNAP!



OK YOU JUST LOST YOUR ENGINE!



JUST ANOTHER DAY AT THE OFFICE.



AND WHAT DID YOU JUST DO?



CHAMBERS YOU ARE THREE THOUSAND FEET IN THE AIR. YOU HAVE JUST LOST YOUR ENGINE AND YOU REACH OVER AND SET THE @\*!# PARKING BRAKE!?



110115

This method is how I go about checking CG on a plane that weighs too much to put on a CG machine. This is generally the same way full scale planes are balanced as you can't go lifting a 747 by your fingers!

First, have the plane assembled as RTF, but minus fuel. Find a place where you can put the nose of the plane up against a wall. Take a level and prop up the tail wheel until the fuselage is sitting level. Once the plane is sitting level, place masking tape under the area where the main wheels are touching the surface and draw a line where the wheels contact the tape. Make an index mark where the center of the tailwheel falls in the same manner. What you are looking for at this point is the distance to each wheel marking from the tip of the spinner (which should be touching the wall at this point). I use a long straightedge to get the distances

As an example, let's say you come up with these numbers:

LH main – 22"

RH main – 22"

Tailwheel – 70"

Now, place a scale under each wheel individually. You will have to re-adjust the height of the other wheels each time to keep the plane sitting level.

Let's say you come up with these numbers

LH main – 9 lbs

RH main – 9 lbs

Tailwheel – 5 lbs

Now its just a simple math problem to find where the CG sits right now on the plane.

Weight x ARM (distance) = Moment

$22 \times 9 = 198$  in-lbs

$22 \times 9 = 198$  in-lbs

$70 \times 5 = 350$  in-lbs

Now add the total of all the moments and the total of all the weights.

Weights  $9 + 9 + 5 = 23$  lbs

moments  $198 + 198 + 350 = 746$

Then divide the total moments by the total weights.

$746$  divided by  $23 = 32.43$

That number 32.43 is "in inches" how far back from the tip of the spinner to where the plane balances right now.

Check this mark against the recommended C of G setting to see if you need add weights/readjust battery positions etc.

It may sound confusing and a lot of work but it really only takes about ten minutes to do it.

### Hint from Paul Dodge

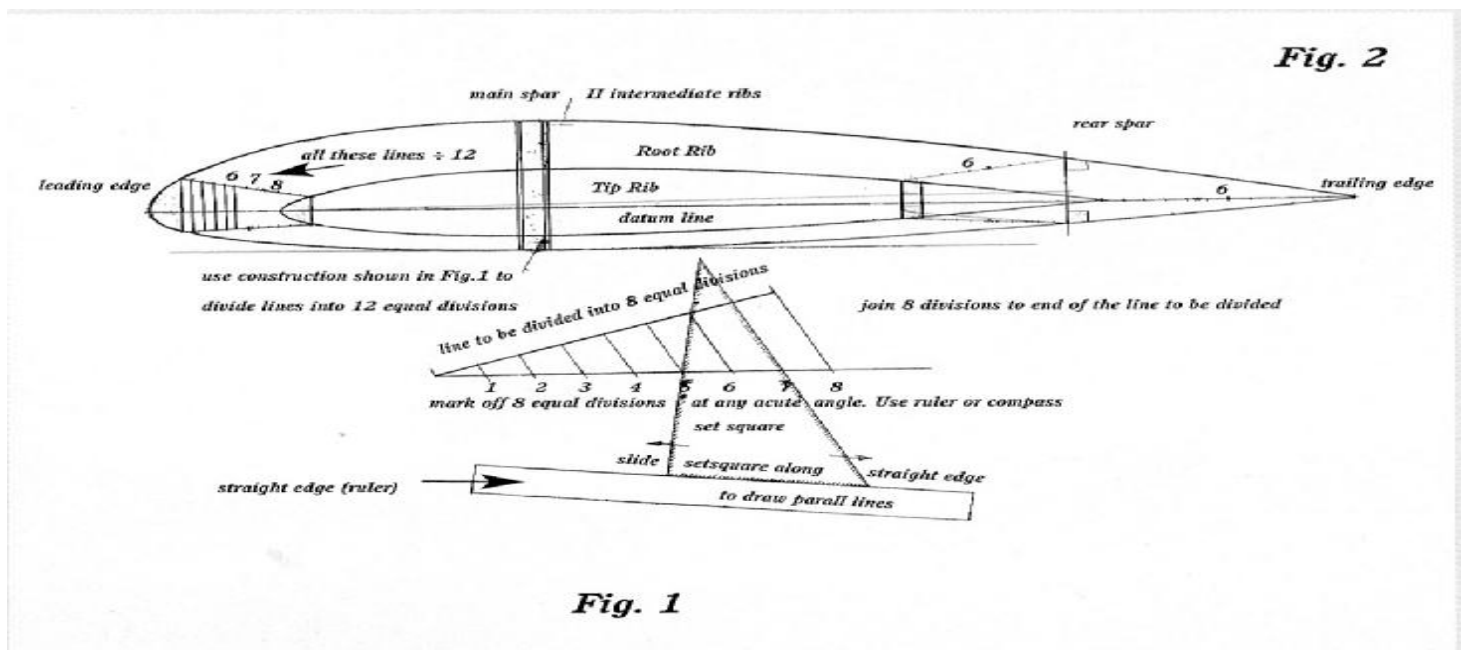

A means of positioning and shaping ribs for the scratch builders.

Just takes you back to school days Geometry.



Les Fenn's Spitfire on take-off roll



Dave McNair and foam Sabre. A very realistic model.

<http://www.gscmar.com/index.jsp>

If anyone feels like an Interstate trip, this looks like a good rally. Pity that we don't have an El Cheapo instant connection.



Now and again someone comes up with something funny. The big companies probably don't care much either way, but David is still alive and well, so is Goliath for that matter.

# MASTERING STRAIGHT LINES AND TURNS

*How the pros make it look easy*

by David Scott

Our good friend Dave Scott is going to take us step by step through flying a plane in a straight line and making a textbook, picture-perfect procedure turn. Dave is the flight instructor for the 1st U.S. R/C Flight School as well as a full-size aerobatic pilot. His insight into flying aircraft is derived from his personal accomplishments and from teaching thousands of students at his school. Enjoy.

## INTRODUCTION

When most people learn to drive a car, they work hard to keep the car going straight. This is mostly due to holding in the steering wheel corrections too long and trying to “steer” the car straight. Yet, after a while we’re able to keep the car straight with very little effort. The reason is that we develop an appreciation for the fact that most deviations can be corrected with a

nudge upon the wheel, and we’re confident that if one nudge doesn’t do the trick we can always apply another. Thus, applying small nudges to the steering wheel produces straighter lines and reduces the number of corrections we have to make. Small, brief bumps of aileron or rudder (not held in) have precisely the same effect to help us fly straighter lines, as well as make small course changes without over-controlling.

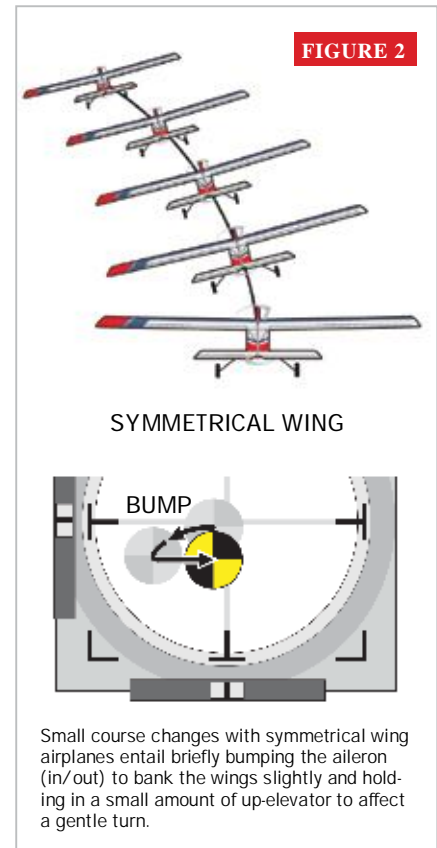
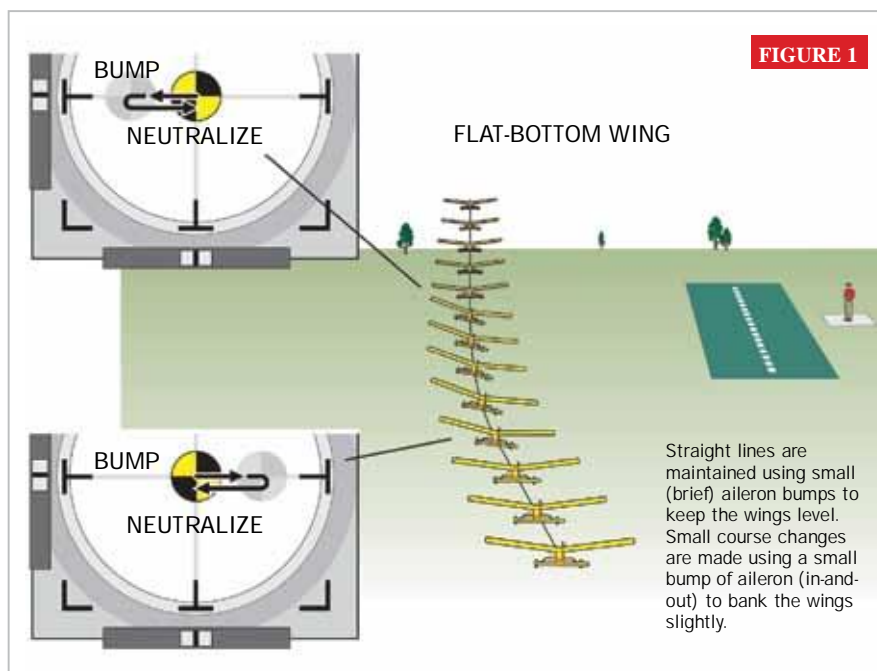

## BUMP APPLICATIONS

Proficient pilots use small bumps of aileron to keep the wings level in order to maintain straight lines. Bumps are also used to bank the wings slightly and cause an airplane to drift slightly to the left or to the right (Figure 1). As long as the bumps are not too large or held in, the airplane won’t lose altitude after a bump so there is no need for elevator when making small course changes. If the airplane features a symmetrical airfoil wing, the course change after an aileron bump, will tend to be much more gradual. To affect a more deliberate course change with a symmetrical wing plane, the pilot must also pull a little up-elevator and, in effect, perform a mini procedure turn (Figure 2).

Because the bump is small, it must be applied and returned to neutral smoothly to give the plane time to respond. Quickly

jabbing the aileron will likely produce little or no response. Keep in mind that the slight wing bank and gradual course change after a smooth, small bump may not be immediately obvious. Thus, you must pause for a few moments after each bump to be certain whether another bump is needed. Remember, over-controlling is usually not caused by aggressive inputs at first, but is the result of holding an input in too long and occurs most often when pilots hold in their inputs waiting to see an obvious reaction of the plane. Therefore, it's better to make two separate bumps, if necessary, rather than hold in the aileron! Bumping the rudder on airplanes without ailerons works just as well, but rudder bumps must be applied very smoothly to have the desired effect. The bump technique works great for gradual course adjustments up to 20 to 30 degrees. A larger course change will require a deliberate turn involving aileron and elevator.

As pilots (like drivers) become more relaxed, they start noticing deviations off the intended path the instant they occur, thus the corresponding bumps become so small that anyone watching won't even be able to tell that corrections are being made. That's one of the main reasons why really good pilots make flying look so easy.

#### FLYING BETTER STRAIGHT LINES AND A PARALLEL FOUNDATION

If you have ever watched proficient pilots fly (you can tell by their ability to perform one maneuver after another), you may have noticed the absence of visible corrections between their maneuvers—often referred to as being smooth. The primary reason for their smooth flying is that they possess a solid foundation of flying consistent parallel lines with the runway.

Establishing a parallel foundation starts with picturing the comfortable viewing distance where you want the airplane to be when it passes in front of you, otherwise known as "show center." Then, project that distance out to your left and right parallel with the runway and pick some ground reference "targets" on the horizon to use as parallel turnaround points (Figure 3). Guiding your airplane toward these points will greatly add to your consistency in the air.

#### CROSSWIND POSITIONING BASICS AND OBJECTS AS A WHOLE

As a rule, an airplane will fly in a straight line whenever the wings are level. If a cross-

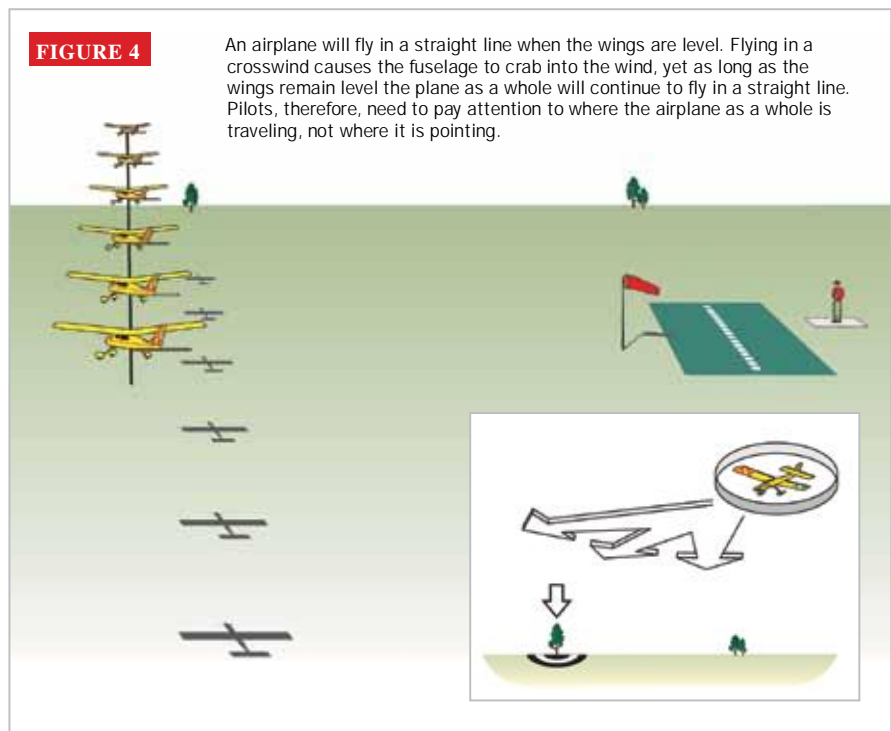
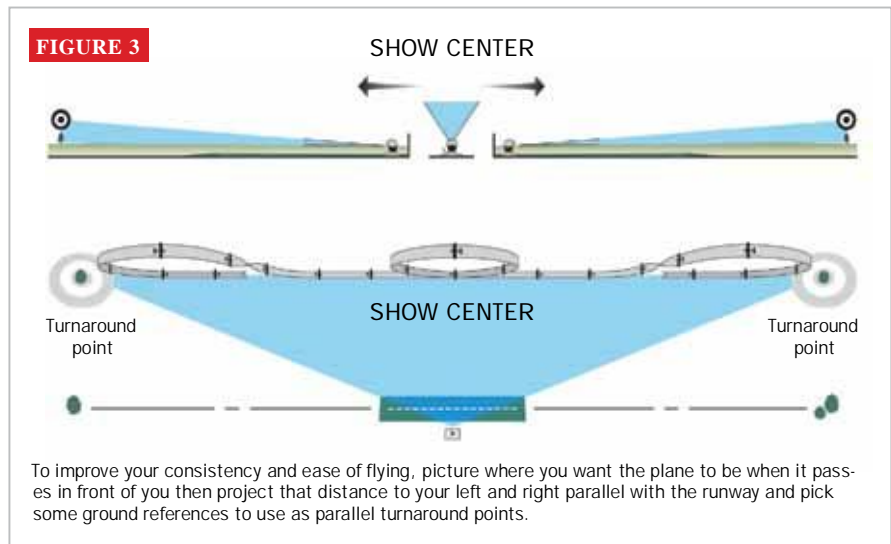

wind exists, the plane will crab (point) into the wind a bit, but as long as the wings remain level, it will continue to track straight. From the ground, the position of the wings can often be difficult to judge, so rather than relying on the positions of the wing or fuselage, proficient pilots concentrate on where the airplane "as a whole" is traveling (Figure 4).

It is easy to see deviations when guiding the airplane as a whole toward a distinct target on the horizon. It's a bit trickier on the return path to show center. To detect deviations from parallel after turning around, keep your eye on where the airplane as a whole is traveling relative to yourself. That is, ask yourself, "Is it drifting away from

me?" (bump it in). "Is it drifting toward me?" (bump it out). When neither a deviation nor away from you is detected, the airplane will be tracking generally parallel with the runway (Figure 5).

While wind is often blamed for deviations, it's actually the wind's principle effect that helps to exaggerate deviations and mistakes that pilots can otherwise get away with in calmer conditions. For example, when a crosswind exists, amateur pilots often make the mistake of completing their turns when the plane points where they want it to go, and then input a crab into the wind after they detect wind drift. The correct method is to finish your turns a little early or late so that the required crab angle

# FUN FLY-IN

scale  
model aircraft



**free admission  
all long weekend  
28th ~ 30th Oct**

*Please Ring  
Grahame Woodcock - 0438 673 174  
Scott Pittick - 0488 142 352  
Anthony Amadio - 0421 211231  
or visit [www.swarms.org.au](http://www.swarms.org.au)  
for further details*

*Saturday Night  
BBQ @ 6.00pm  
(Please RSVP)*



**Every Pilot who  
flies is entered into  
the draw for a  
DLE-20 Engine!**

**everyone  
welcome**

**food, drinks & overnight  
camping available**

*Friday Public Holiday - Open Field  
Saturday 8.00am Fun Fly - All Models  
Sunday - 9.00am Scale Fun Fly  
(any scale style inc Jet, Heli, ARF etc)  
Pilots Brief @ 9.30am Sat & Sun*

